

Servo Slowdown Based on PICAXE-08M Microcontroller

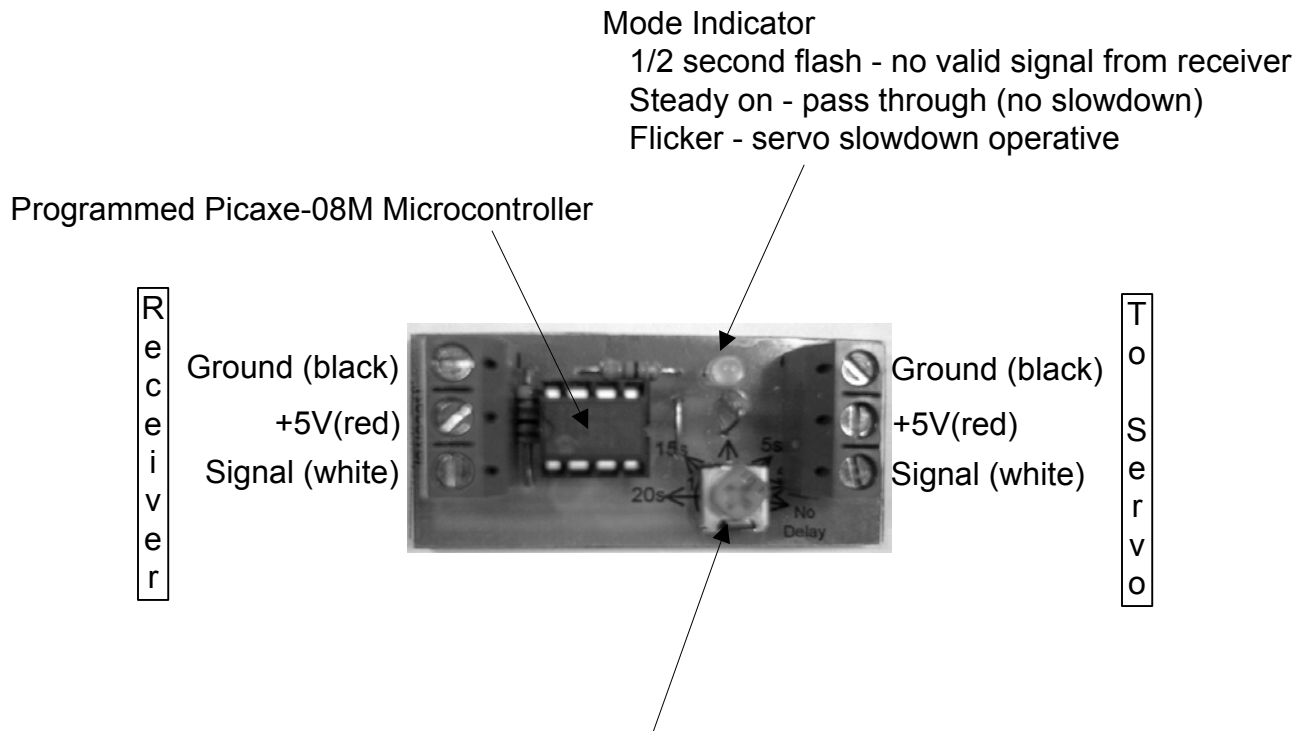

Speed Adjust

Changes to the slowdown rate will only become operative after power is removed and restored (i.e. receiver turned off and back on)

Fully anti-clockwise

Maximum slowdown (approx 20 seconds for end-to-end travel)
to

3/4 clockwise

Minimum slowdown (approx 3 seconds for end-to-end travel)
to

Fully anti-clockwise

No slowdown (as without the servo slowdown device)

Caution:

**Do not use with >5.4V supply to the receiver (some run on 6v).
It will likely destroy the microcontroller**